

NOTES:

1. MADE TO QUEENSLAND MAIN ROADS MRTS91
2. CIRCULAR COVER TO MEET AS 3996:2019 CLASS B DESIGN LOAD AND THE REQUIREMENTS OF MRTS91
3. AVAILABLE IN ELECTRICAL 11549, COMMUNICATIONS 11550 & TRAFFIC SIGNAL (FOR ROADS AND MARITIME SERVICES & BRISBANE CITY COUNCIL REQUIREMENTS) 11817

COMMUNICATIONS

ELECTRICAL

TRAFFIC SIGNAL

VIEW ON
NAME PLATE OPTIONS
(1:5)

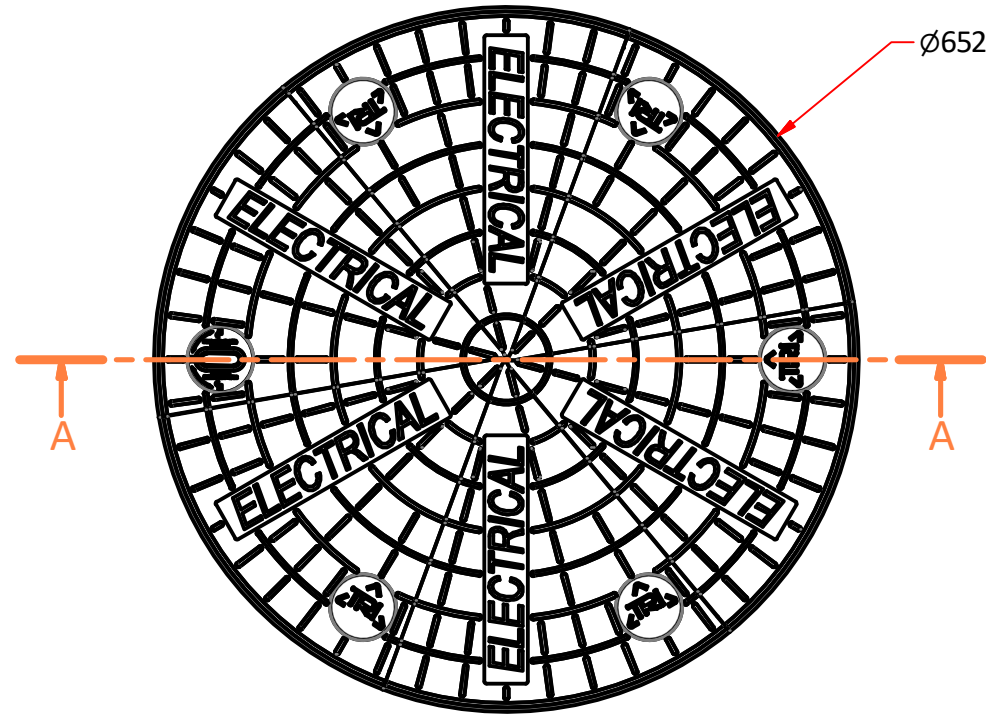

PLAN VIEW (1:7)

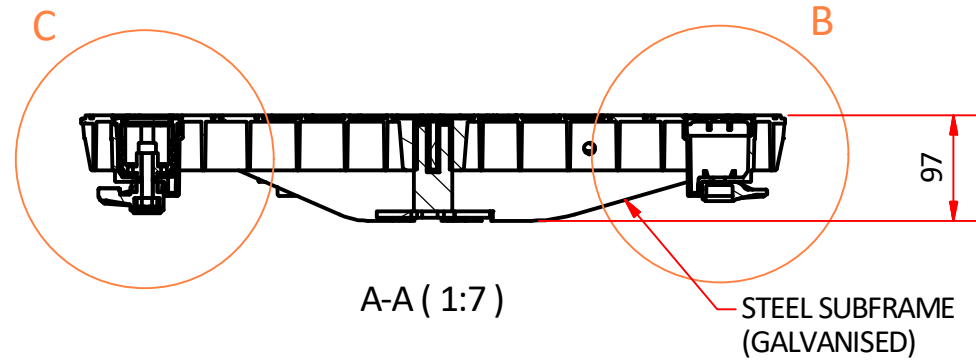

A-A (1:7)

STEEL SUBFRAME
(GALVANISED)

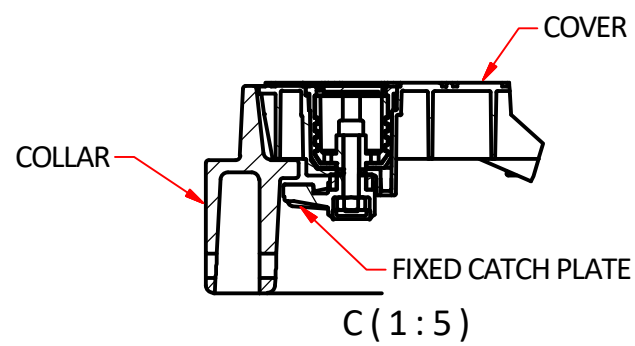

C (1:5)

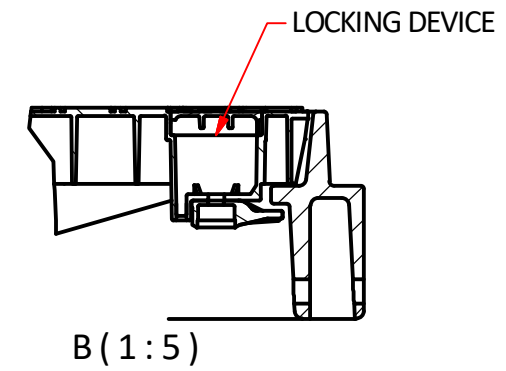

B (1:5)

General Notes;

1. All dimensions are in mm
2. Tolerance on all dimensions ± 1 mm unless stated otherwise

Copyright: TRI Underground Australia Pty Ltd

This instruction and all the information herein is the property of TRI Underground PTY LTD. It must not be copied, made public or used directly or indirectly, including manufacture of the product shown herein, without written approval. This instruction is loaned subject to these conditions and subject to return on demand.

Commercial in confidence

	Material NYLON / STEEL	Designed by IMD	Checked by HL	Approved by HA	Date 5/07/2022	Date 22/01/2022	
	Weight APPROX. 10 kg	TRI Underground Australia			Title T60 TRITUFF LID		
	Finish OFF MOULD				Dwg No. 11549	Edition A	Sheet 1 / 1