

NOTES:

1. MADE TO QUEENSLAND MAIN ROADS MRTS91 AND SD1695
2. WALL THICKNESS TO BE 14 ±2 mm
3. THE HEIGHT SHALL BE 1200 ±10 mm
4. PIT MEETS CLASS B LOAD RATING AS PER AS3996:2019
5. PIT ALSO AVAILABLE IN A 1000 mm DEEP OPTION
6. PIT TO BE FITTED WITH T60 CIRCULAR COLLAR CLASS B  
REFER TO TRI DRAWING 10408 & 11656 AND T60 CLASS B COVER  
REFER TO DWG 11549 AND 10410
7. IDENTIFYING LABELS TO BE AT 300 mm AND 600 mm DOWN
8. SPLIT PIT WITH COMPOSITE COLLAR OPTION ALSO AVAILABLE  
TRI CODE 14871
9. COLLAR TO BE PLACED ON THE PIT PRIOR TO COMPACTION  
OF THE BACK FILL MATERIAL
10. WEIGHT SHOWN IS REFLECTIVE OF PIT AND CAST IRON COLLAR

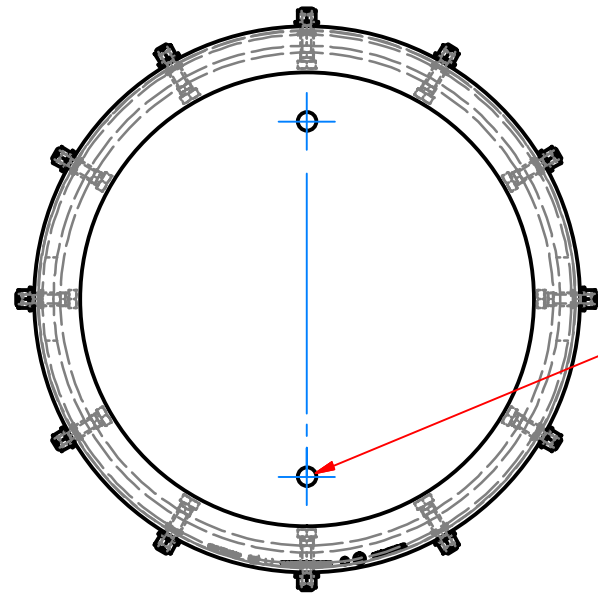

TOP VIEW ( 1:10 )

x2 Ø25 DRAIN HOLES  
IN BASE

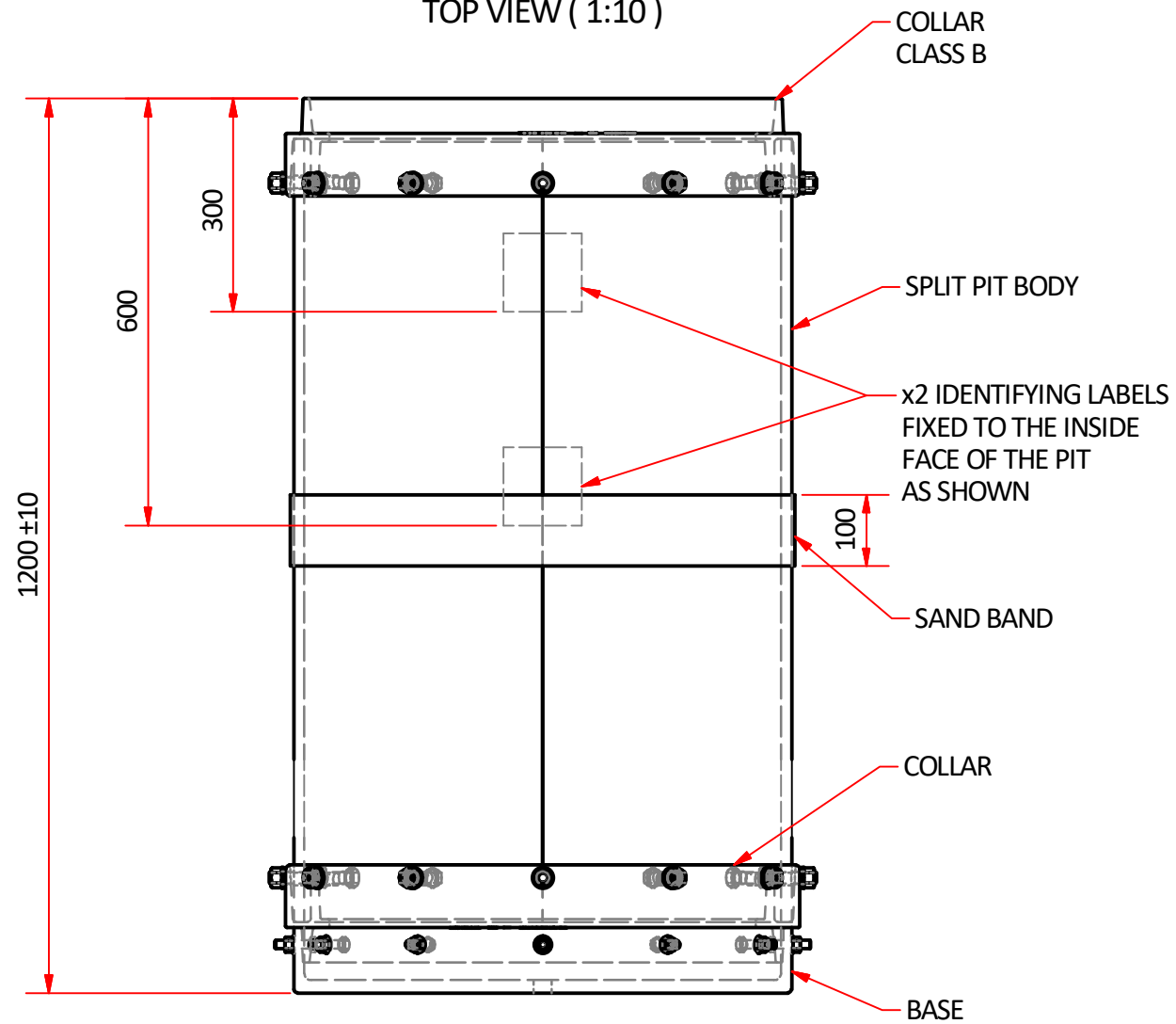

FRONT VIEW ( 1:10 )

Copyright: TRI Underground Australia Pty Ltd

This instruction and all the information herein is the property of TRI Underground PTY LTD. It must not be copied, made public or used directly or indirectly, including manufacture of the product shown herein, without written approval. This instruction is loaned subject to these conditions and subject to return on demand.

Commercial in confidence



Material  
LDPE/POLYPROPYLENE

Weight  
APPROX. 80 kg

Finish  
OFF MOULD

Designed by  
IMD

Checked by

Approved by

Date

Date

20/01/2022

TRI Underground Australia

Title T60 1.2 m SPLIT PIT - CAST IRON COLLAR

Dwg No.  
14870

Edition  
A

Sheet  
1 / 2