

NOTES:

1. MADE TO QUEENSLAND MAIN ROADS SD1416,
2. MATERIAL TYPE AND THICKNESS TO MEET AS3996:2019 CLASS B DESIGN LOAD AND THE REQUIREMENTS OF MRTS91,
3. CIRCULAR COLLAR TO SUIT T100 CIRCULAR PIT - REFER TO DRAWING 14840,
4. USE 12 GALVANISED M16x60 HEX HEAD BOLTS WITH 2 WASHERS EACH, ONE NEXT TO THE NUT AND ONE NEXT TO THE SQUARE SECTION UNDERNEATH THE HEX HEAD TO PERMANENTLY ATTACH COLLAR TO THE PIT.
5. HEX HEADS ARE ON THE INSIDE OF THE PIT.
6. ALL FIXINGS GALVANISED TO AS4680
7. COLLAR MUST BE INSTALLED WITH EXPANSION JOINT FOAM ROLL (50x10)

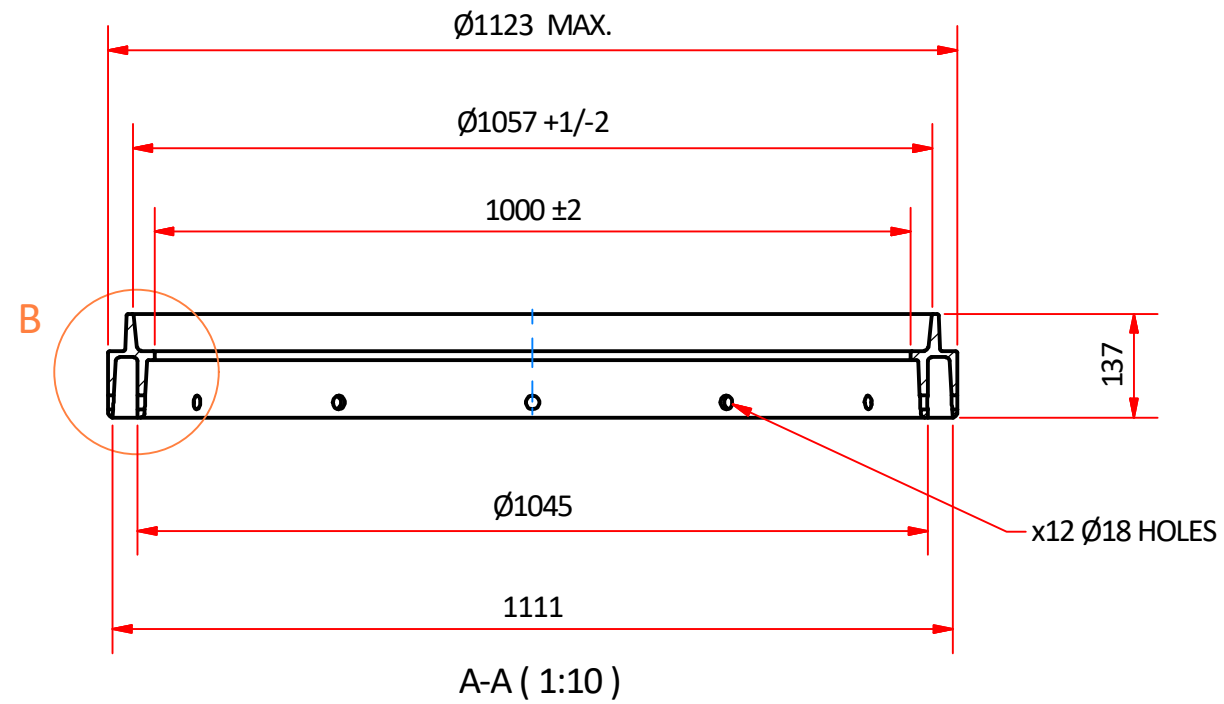
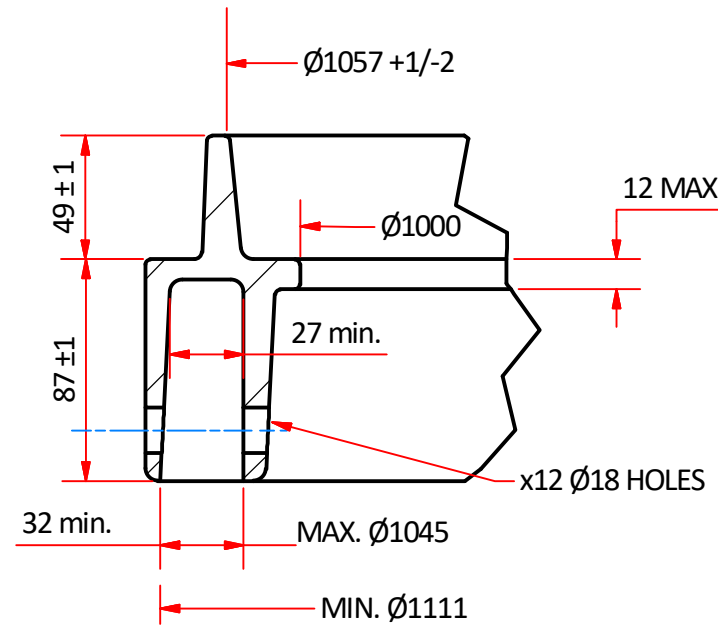
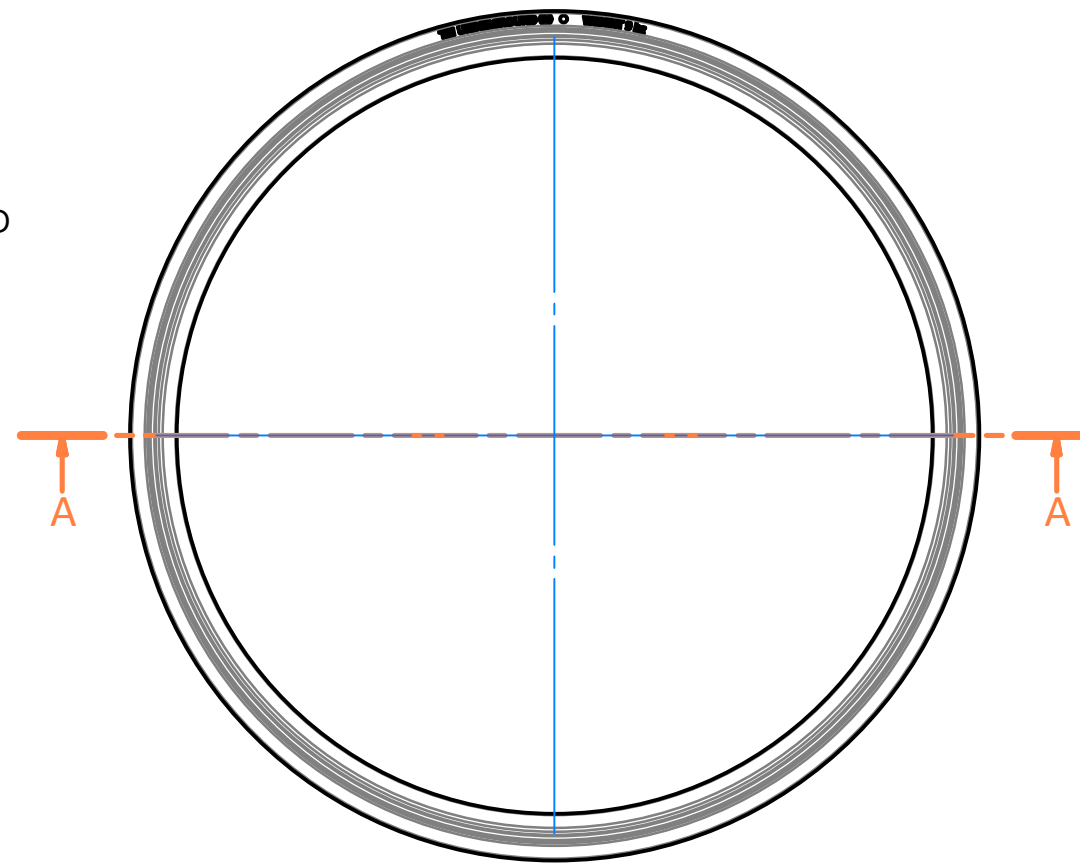

General Notes;

1. All dimensions are in mm
2. Tolerance on all dimensions ± 1 mm unless stated otherwise

Copyright: TRI Underground Australia Pty Ltd

This instruction and all the information herein is the property of TRI Underground PTY LTD. It must not be copied, made public or used directly or indirectly, including manufacture of the product shown herein, without written approval. This instruction is loaned subject to these conditions and subject to return on demand.

Commercial in confidence

	Material POLYPROPYLENE	Designed by IMD	Checked by HL	Approved by HA	Date 5/07/2022	Date 22/01/2022
	Weight APPROX. 9 kg	TRI Underground Australia			Title T100 TRITUFF COLLAR	
	Finish OFF MOULD				Dwg No. 14841	Edition A