

NOTES:

1. SUPPORTS MINOR ROAD DECORATIVE NOSTALGIA 1 & 2
2. ENERGEX STOCKCODE 000022400
3. MADE WITH A RAGBOLT 4 BOLT 350 PCD N24 W/TH M20 THREAD 1.5 m
4. BEND INSIDE IS A 40 H/D ORANGE BEND 150 RADIUS 90 DEGREE FFS C/W 765 mm STRAIGHT
5. FOOT ANCHORS 1.3T x 120 mm
6. MADE WITH 40 MPa CONCRETE

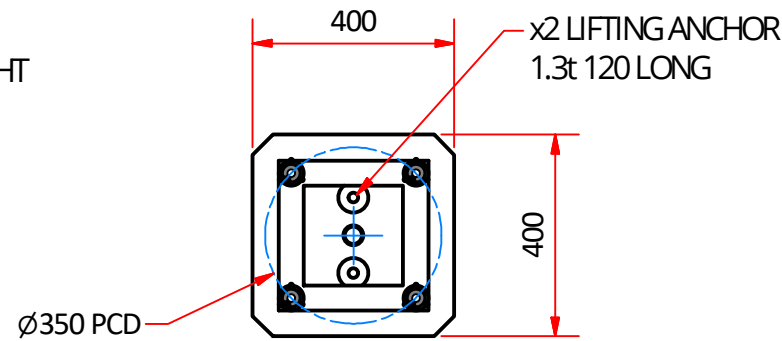

TOP VIEW (1:15)

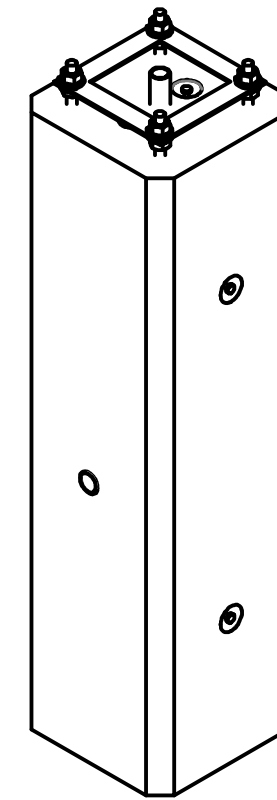

3D VIEW (1:15)

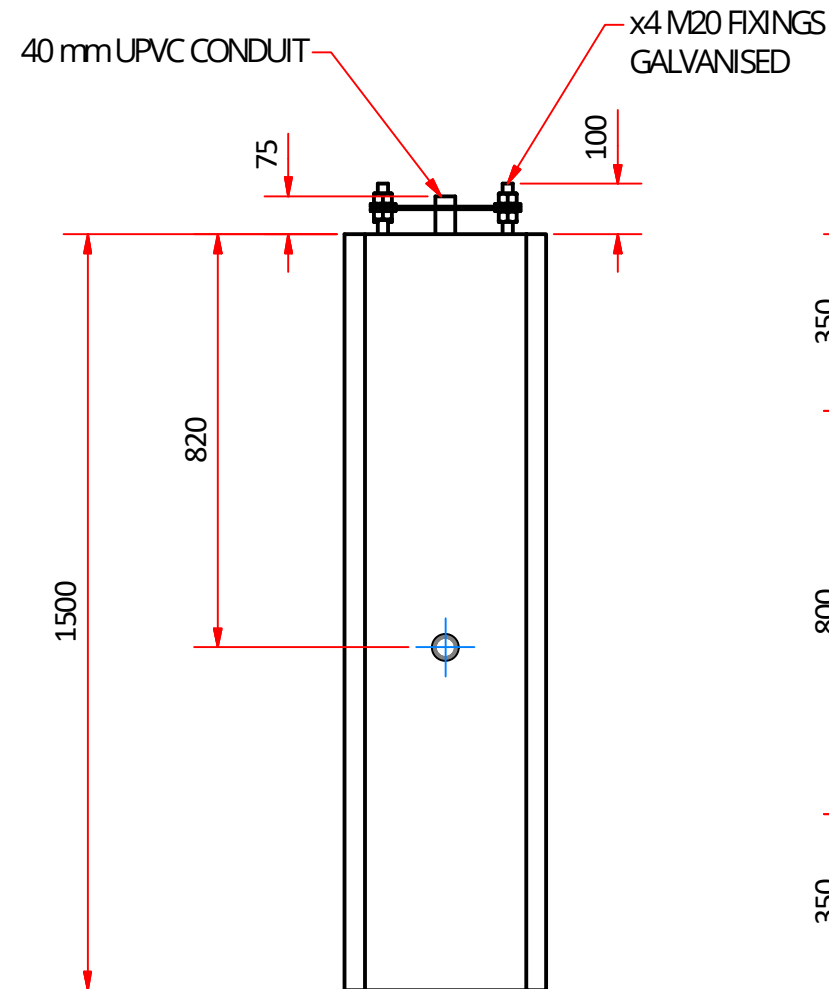

FRONT VIEW (1:15)

RH SIDE VIEW (1:15)

General Notes;

1. All dimensions are in mm
2. Tolerance on all dimensions ± 3 mm unless stated otherwise

Copyright: TRI Underground Australia Pty Ltd

This instruction and all the information herein is the property of TRI Underground PTY LTD. It must not be copied, made public or used directly or indirectly, including manufacture of the product shown herein, without written approval. This instruction is loaned subject to these conditions and subject to return on demand.

Commercial in confidence

	Material CONCRETE	Designed by IMD	Checked by HL	Approved by HA	Date 23/03/2022	Date 22/01/2022
	Weight APPROX. 550 kg	TRI Underground Australia			Title PRECAST FOUNDATION 1500 mm 4 BOLT 350 PCD	
	Finish OFF MOULD				Dwg No. 13686	Edition A